

SCHWAIGER[®]

TV WANDHALTER
TV WALL MOUNTS

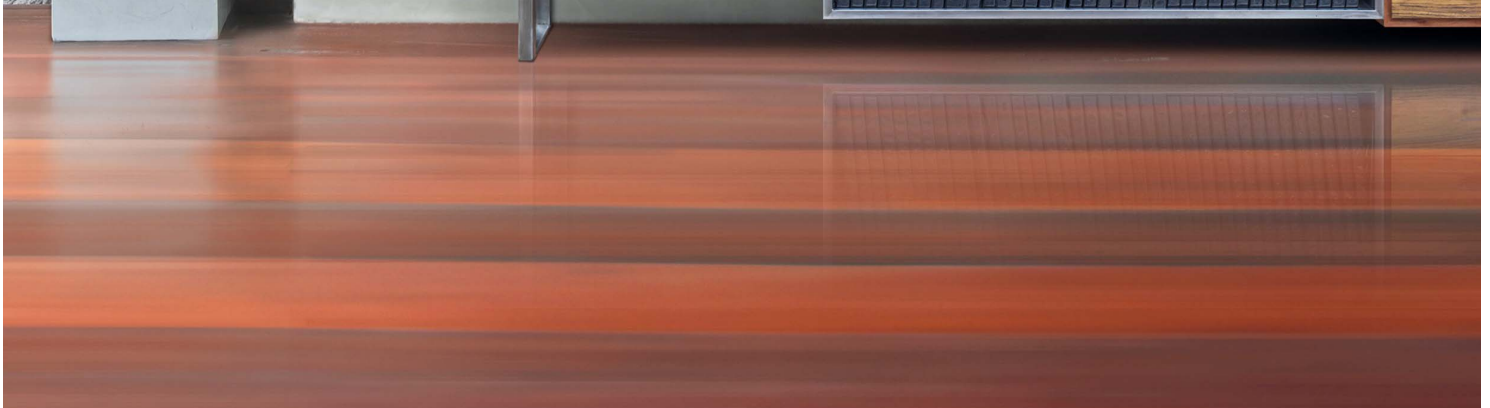

VESA NORM:**WAS BEDEUTET DAS?**

Die VESA Norm ist der internationale Befestigungs-Standard von LCD-, LED- und Plasma- TV-Geräten. Am Gerät ist beschrieben, ob es mit dem VESA Standard ausgerüstet ist, Sie können es aber auch sehr leicht selbst feststellen, indem Sie den Abstand der Gewindebohrungen auf der Rückseite messen. Damit finden Sie die passende Halterung für Ihr Gerät.

Im Beispiel beträgt die VESA Norm 200 x 200 mm.

VESA NORM:**WHAT DOES THAT MEAN?**

The VESA standard is the international mounting standard for LCD, LED and plasma TV sets. It is described on the device whether it is equipped with the VESA standard, but you can also easily determine it yourself by measuring the distance between the threaded holes on the rear side. This will help you to find the right holder for your device.

In the example the VESA standard is 200 x 200 mm.

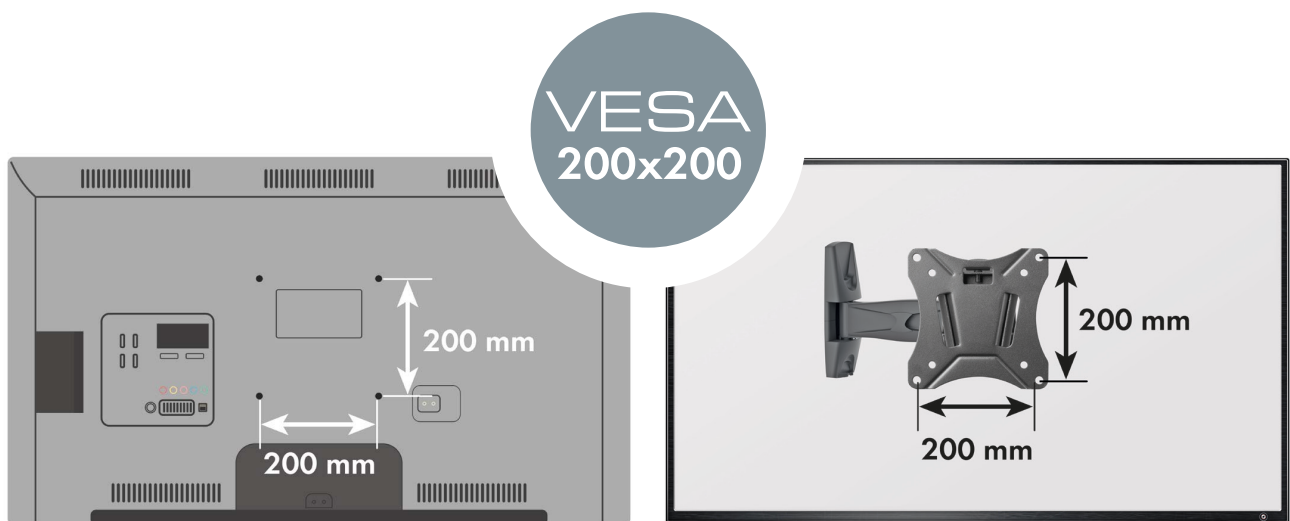

Die VESA Norm des jeweiligen Wandhalters können Sie unseren technischen Daten entnehmen. Sie wird immer in Millimeter angegeben.

The VESA standard of the respective wall bracket can be found in our technical data. It is always given in millimeters.



QR Code scannen und Video ansehen
Scan QR code and watch video

VIDEO-TUTORIALS:

Für viele unserer Wandhalter haben wir für Sie auf unserem YouTube-Kanal eine Playlist erstellt, in der Sie Videos zu Montage und Aufbau finden. Scannen Sie den QR Code und sehen Sie genau, wie die Halter montiert werden.

For many of our wall mounts, we have created a playlist for you on our YouTube channel, in which you will find videos on mounting and assembly. Scan the QR code and see exactly how the holders are mounted.



LWHD5530 511

ULTIMATE

TV Wandhalter "FULL MOTION 1" | TV Wall Mount "FULL MOTION 1"

zur individuellen und flexiblen Bildschirmpositionierung | for individual and flexible screen positioning

- Halterung für einen Flachbildschirm (LCD, LED, TFT, Plasma)
- Leichte Einstellung in die ergonomisch richtige Position
- Gelenke in der Festigkeit einfach verstellbar
- Stabile Ausführung
- Gasdruckfeder-Technologie ermöglicht eine leichtgängige Verstellung ohne Knöpfe oder Hebel
- Kabelführung integriert
- Einfache Installation und Handhabung
- Montage nur an stabilen Wänden
- Lieferumfang: Wandhalter, Montagezubehör, Bedienungsanleitung
- mount for a flat screen (LED, LCD, TFT or plasma screen)
- easy adjustment to the ergonomically correct position
- hinges can easily be tightened or loosened
- solid design
- Gas-spring technology allows easy adjustment without button or levers
- integrated cable gland
- easy installation and handling
- installation on sturdy walls only
- content: wall mount, installation accessories, user manual



Technische Daten | Technical data

VESA Norm	75 x 75/100 x 100/200 x 100/200 x 200/300 x 300/400 x 200/400 x 400
VESA norm	75 x 75/100 x 100/200 x 100/200 x 200/300 x 300/400 x 200/400 x 400
Wandabstand Wall distance	58 - 595 mm 58-595 mm
Tragarm Support arm	Schwenkarm mit 3 Gelenken swivel arm with 3 hinges
Höhenverstellbar height adjustable	320 mm 320 mm
Neigbar (vertikal) Tilttable (vertically)	+10° bis -20° +10° to -20°
Schwenkbar (horizontal) Swivelling (horizontal)	360° 360°
Drehbar (axial) Swivelling (axial)	+3 bis -3° +3 to -3°
Belastbarkeit Capacity	30 kg 30 kg
Farbe Colour	Schwarz black
Produktmaterial Material of product	Aluminium pulverbeschichtet Aluminium powder-coated
Gewicht Weight (set)	5,2 kg 5,2 kg
Abmessungen (Breite)	420 mm

Dimensions (width)	420 mm
Abmessungen (Höhe) Dimensions (height)	420 mm
Abmessungen (Tiefe) Dimensions (depth)	58 mm 58 mm
Garantie Guarantee	5 Jahre Gewährleistung 5-year guarantee

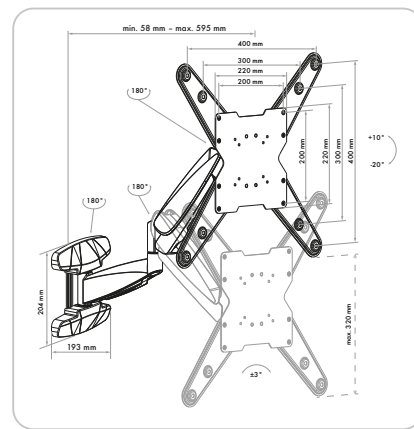

30
kg

VESA
max. 400

58-595
mm

+10°--20°

180°

±3°

320mm

GAS SPRING

BUBBLE LEVEL

QUICK CONNECT HOLE

140cm
23"-55"



Art. Nr. Art. No.	EAN EAN	Verpackungsart Packaging
LWHD5530 511	4004005011647	Karton carton



LWHT246 513

ULTIMATE

Monitor Tischhalter "FULL MOTION 2" | Desk mount monitor arm "FULL MOTION 2"

für zwei Monitore | for two Monitors



- Tischhalter mit Doppeltragarm und je einem USB Anschluss
 - Vergrößerung der Arbeitsfläche auf dem Schreibtisch
 - Leichte Einstellung in die ergonomisch richtige Position
 - Gasdruckfeder-Technologie ermöglicht eine leichtgängige Verstellung ohne Knöpfe oder Hebel
 - Anordnung der Bildschirme im Landscape-Modus (nebeneinander) oder im Portrait-Modus (übereinander)
 - Kabelführung integriert
 - Stabile Ausführung
 - Einfache Installation und Handhabung
 - Montage nur an stabilen Arbeitsplatten von 10 bis 85 mm Stärke
 - Lieferumfang: Tischhalter, Montageanleitung und -zubehör
- table holder with double support arm and one USB port per support arm
 - enlargement of the working space on the desk
 - easy adjustment to the ergonomically correct position
 - Gas-spring technology allows easy adjustment without button or levers
 - arrangement of the screens in the landscape mode (side by side) or in portrait mode (stacked)
 - integrated cable gland
 - solid design
 - easy installation and handling
 - mounting only stable countertops from 10 to 85 mm thickness
 - content: desk mount monitor arm, installation instructions and accessories



Technische Daten | Technical data

VESA Norm	75 x 75/100 x 100	Gewicht	4,5 kg
VESA norm	75 x 75/100 x 100	Weight (set)	4,5 kg
Tragarm	Doppelter Schwenkarm mit je 4 Gelenken	Garantie	5 Jahre Gewährleistung
Support arm	double swivel arm with 4 hinges	Guarantee	5-year guarantee
Höhenverstellbar	90 - 410 mm		
height adjustable	90 - 410 mm		
Neigbar (vertikal)	+90° bis -90°		
Tilttable (vertically)	+90° to -90°		
Schwenkbar (horizontal)	360°		
Swivelling (horizontal)	360°		
Drehbar (axial)	360°		
Swivelling (axial)	360°		
Belastbarkeit	6 kg je Tragarm		
Capacity	6 kg per support arm		
Farbe	Schwarz		
Colour	black		
Produktmaterial	Aluminium pulverbeschichtet		
Material of product	Aluminium powder-coated		

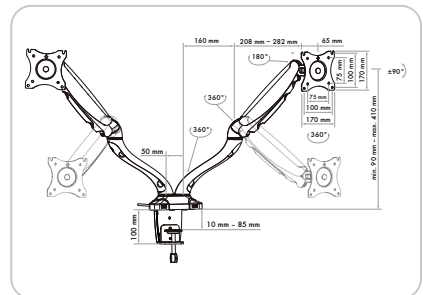

Art. Nr.	EAN	Verpackungsart
Art. No.	EAN	Packaging
LWHT246 513	4004005011494	Karton carton

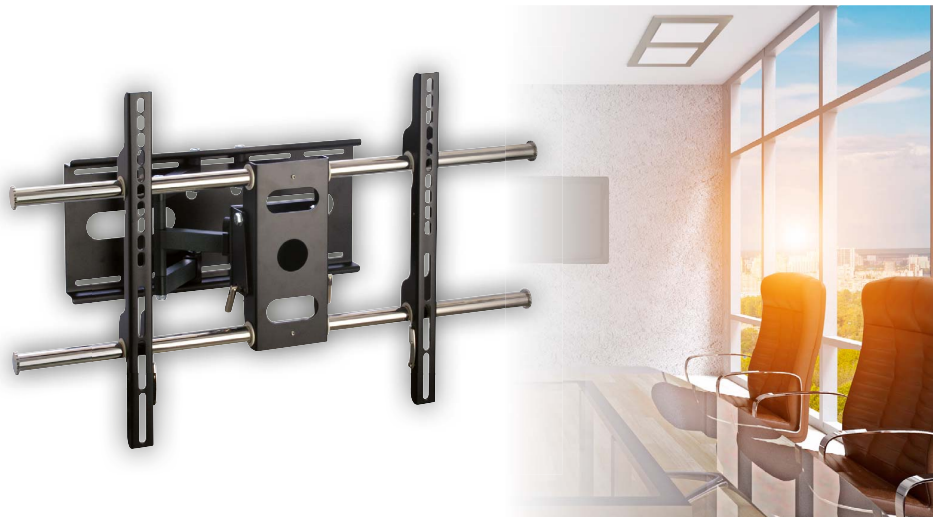

LWH603D 011

ULTIMATE

Profi 3D Wandhalter | Professional 3D Wall Mount

für Flachbildschirme (94 - 178 cm) | for Flat Screens (94 - 178 cm)



- Halterung für einen Flachbildschirm (LCD, LED, TFT, Plasma)
 - Einfache Montage durch CLICK & SAVE System
 - Montage nur an stabilen Wänden
 - Geprüfte Sicherheit (TÜV und GS)
 - Sehr stabile Ausführung
 - Lieferumfang: Wandhalter, Montagezubehör, Bedienungsanleitung
- mount for a flat screen (LED, LCD, TFT or plasma screen)
 - easy installation through CLICK & SAVE system
 - installation on sturdy walls only
 - TÜV and GS certified
 - very solid design
 - content: wall mount, installation accessories, user manual

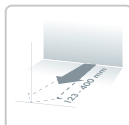
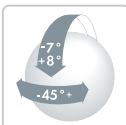

Technische Daten | Technical data

VESA Norm	max. 800	Abmessungen (Höhe)	505 mm
VESA norm	max. 800	Dimensions (height)	505 mm
Wandabstand	123 - 400 mm	Abmessungen (Tiefe)	123 mm
Wall distance	123-400 mm	Dimensions (depth)	123 mm
Tragarm	Schwenkarm mit 2 Gelenken	Garantie	5 Jahre Gewährleistung
Support arm	swivel arm with 2 hinges	Guarantee	5-year guarantee
Neigbar (vertikal)	15°		
Tiltable (vertically)	15°		
Schwenkbar (horizontal)	-45° bis +45°		
Swivelling (horizontal)	-45° bis +45°		
Belastbarkeit	60 kg		
Capacity	60 kg		
Farbe	Schwarz		
Colour	black		
Produktmaterial	Metall pulverbeschichtet		
Material of product	rostfrei metal powder-coated stainless		
Gewicht	9,1 kg		
Weight (set)	9,1 kg		
Abmessungen (Breite)	845 mm		
Dimensions (width)	845 mm		

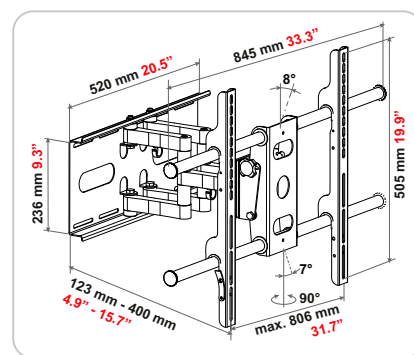

Art. Nr.	EAN	Verpackungsart
Art. No.	EAN	Packaging
LWH603D 011	4004005603798	Karton carton

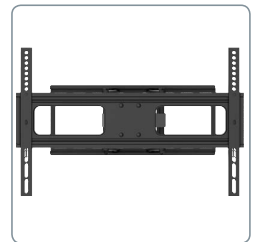

LWHD7050 513

ULTIMATE

TV Wandhalter "MOTION 5" | TV Wall Mount "MOTION 5"

- 50 kg
- VESA max. 600
- 64-510 mm
- +10° -20°
- 120°
- ±3°
- 218 mm
37" - 86"



für 50 kg Gewicht, neigbar, schwenkbar, drehbar | for 50 kg of weight, tiltable, swiveling, rotating

- Halterung für einen Flachbildschirm (LCD, LED, TFT, Plasma)
- Ausziehbarer Doppeltragrahm für verschiedene Betrachtungswinkel
- Gelenke in der Festigkeit einfach verstellbar
- Nach vorn neigbar
- Nach links und rechts schwenkbar
- Montageplatte drehbar
- Stabile Ausführung
- Einfache Installation und Handhabung
- Lieferumfang: Wandhalter, Montagezubehör, Bedienungsanleitung
- mount for a flat screen (LED, LCD, TFT or plasma screen)
- extendable double support arm for different viewing angles
- hinges can easily be tightened or loosened
- can be tilted forward
- can be swivelling left and right
- rotating mounting plate
- solid design
- easy installation and handling
- content: wall mount, installation accessories, user manual

Technische Daten | Technical data

VESA Norm	200 x 200/300 x 300/400 x 200/400 x 400/600 x 400
VESA norm	200 x 200/300 x 300/400 x 200/400 x 400/600 x 400
Wandabstand Wall distance	64 - 510 mm
Tragrahm Support arm	Doppelter Schwenkarm mit 4 + 1 Gelenken double swivel arm with 4 + 1 hinges
Neigbar (vertikal) Tiltable (vertically)	+10° bis -20° +10° to -20°
Schwenkbar (horizontal) Swivelling (horizontal)	120°
Drehbar (axial) Swivelling (axial)	+3° bis -3° +3° to -3°
Belastbarkeit Capacity	50 kg
Farbe Colour	Schwarz black
Produktmaterial Material of product	Metall metal
Gewicht	7 kg

Weight (set)	7 kg
Abmessungen (Breite) Dimensions (width)	660 mm
Abmessungen (Höhe) Dimensions (height)	430 mm
Abmessungen (Tiefe) Dimensions (depth)	64 mm
Garantie Guarantee	5 Jahre Gewährleistung 5-year guarantee

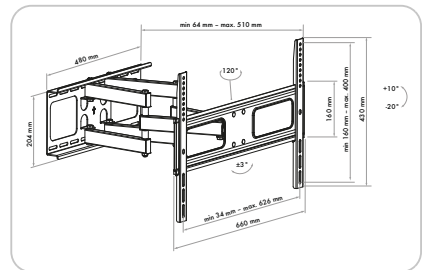

Art. Nr. Art. No.	EAN EAN	Verpackungsart Packaging
LWHD7050 513	4004005011623	Karton carton



LWH35535 513

ULTIMATE

TV Wandhalter "MOTION 4" | TV Wall Mount "MOTION 4"

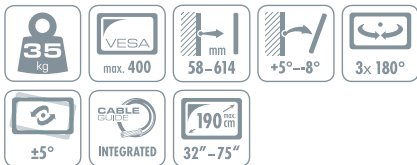

für 35 kg Gewicht, neigbar, schwenkbar, drehbar | for 35 kg of weight, tiltable, swivelling, rotating

- Halterung für einen Flachbildschirm (LCD, LED, TFT, Plasma)
- Ausziehbarer Doppeltragarm für verschiedene Betrachtungswinkel
- Gelenke in der Festigkeit einfach verstellbar
- Kabelführung integriert
- Nach vorn neigbar
- Nach links und rechts schwenkbar
- Montageplatte drehbar
- Stabile Ausführung
- Einfache Installation und Handhabung
- Lieferumfang: Wandhalter, Montagezubehör, Bedienungsanleitung
- mount for a flat screen (LED, LCD, TFT or plasma screen)
- extendable double support arm for different viewing angles
- hinges can easily be tightened or loosened
- integrated cable gland
- can be tilted forward
- can be swivelling left and right
- rotating mounting plate
- solid design
- easy installation and handling
- content: wall mount, installation accessories, user manual

Technische Daten | Technical data

VESA Norm	100 x 100/100 x 150/200 x 100/200 x 200/300 x 200/300 x 300/400 x 200/400 x 300/400 x 400	Weight (set)	3,5 kg
VESA norm	100 x 100/100 x 150/200 x 100/200 x 200/300 x 200/300 x 300/400 x 200/400 x 300/400 x 400	Abmessungen (Breite) Dimensions (width)	410 mm
Wandabstand Wall distance	58 - 614 mm 58-614 mm	Abmessungen (Höhe) Dimensions (height)	410 mm
Tragarm Support arm	Schwenkarm mit 3 Gelenken swivel arm with 3 hinges	Abmessungen (Tiefe) Dimensions (depth)	58 mm
Neigbar (vertikal) Tiltable (vertically)	+5° bis -8° +5° to -8°	Garantie Guarantee	5 Jahre Gewährleistung 5-year guarantee
Schwenkbar (horizontal) Swivelling (horizontal)	3x 180° 3x 180°		
Drehbar (axial) Swivelling (axial)	+5° bis -5° +5° to -5°		
Belastbarkeit Capacity	35 kg 35 kg		
Farbe Colour	Schwarz black		
Produktmaterial Material of product	Aluminium pulverbeschichtet Aluminium powder-coated		
Gewicht	3,5 kg		

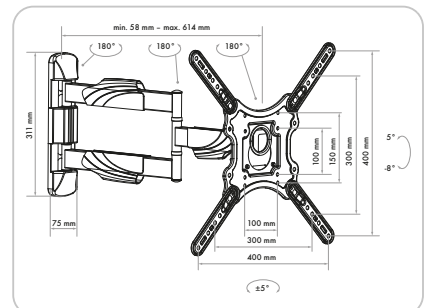

Art. Nr. Art. No.	EAN EAN	Verpackungsart Packaging
LWH35535 513	4004005011593	Karton carton



LWH25535 513

ULTIMATE

TV Wandhalter "MOTION 3" | TV Wall Mount "MOTION 3"

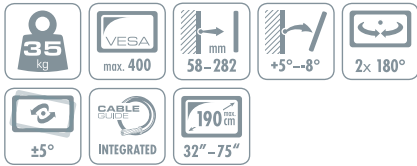

für 35 kg Gewicht, neigbar, schwenkbar, drehbar | for 35 kg of weight, tiltable, swivelling, rotating

- Halterung für einen Flachbildschirm (LCD, LED, TFT, Plasma)
- Ausziehbarer Doppeltragarm für verschiedene Betrachtungswinkel
- Gelenke in der Festigkeit einfach verstellbar
- Kabelführung integriert
- Nach vorn neigbar
- Nach links und rechts schwenkbar
- Montageplatte drehbar
- Stabile Ausführung
- Einfache Installation und Handhabung
- Lieferumfang: Wandhalter, Montagezubehör, Bedienungsanleitung
- mount for a flat screen (LED, LCD, TFT or plasma screen)
- extendable double support arm for different viewing angles
- hinges can easily be tightened or loosened
- integrated cable gland
- can be tilted forward
- can be swivelling left and right
- rotating mounting plate
- solid design
- easy installation and handling
- content: wall mount, installation accessories, user manual

Technische Daten | Technical data

VESA Norm	100 x 100/100 x 150/200 x 100/200 x 200/400 x 400
VESA norm	100 x 100/100 x 150/200 x 100/200 x 200/400 x 400
Wandabstand Wall distance	58 - 282 mm 58-282 mm
Tragarm Support arm	Schwenkarm mit 2 Gelenken swivel arm with 2 hinges
Neigbar (vertikal) Tiltable (vertically)	+5° bis -8° +5° to -8°
Schwenkbar (horizontal) Swivelling (horizontal)	2x 180° 2x 180°
Drehbar (axial) Swivelling (axial)	+5° bis -5° +5° to -5°
Belastbarkeit Capacity	35 kg 35 kg
Farbe Colour	Schwarz black
Produktmaterial Material of product	Aluminium pulverbeschichtet Aluminium powder-coated
Gewicht Weight (set)	2,2 kg 2,2 kg
Abmessungen (Breite) Dimensions (width)	410 mm 410 mm

Abmessungen (Höhe) Dimensions (height)	410 mm 410 mm
Abmessungen (Tiefe) Dimensions (depth)	58 mm 58 mm

Garantie Guarantee	5 Jahre Gewährleistung 5-year guarantee
-----------------------	--

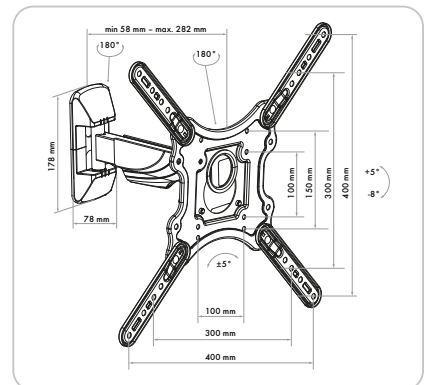

Art. Nr. Art. No.	EAN EAN	Verpackungsart Packaging
LWH25535 513	4004005011586	Karton carton

LWH350 511

ULTIMATE

TV Wandhalter (3 Gelenke) | TV Wall Mount (3 Hinges)

für Flachbildschirme (58 - 107 cm) | for Flat Screens (58 - 107 cm)



- Halterung für einen Flachbildschirm (LCD, LED, TFT, Plasma)
- Einfache Montage durch CLICK & SAVE System
- Montage nur an stabilen Wänden
- Montageplatte drehbar
- Stabile Ausführung
- Lieferumfang: Wandhalter, Montagezubehör, Bedienungsanleitung
- mount for a flat screen (LED, LCD, TFT or plasma screen)
- easy installation through CLICK & SAVE system
- installation on sturdy walls only
- rotating mounting plate
- solid design
- content: wall mount, installation accessories, user manual



Technische Daten | Technical data

VESA Norm	75 x 75/100 x 100/200 x 100/200 x 200	Weight (set)	2,3 kg
VESA norm	75 x 75/100 x 100/200 x 100/200 x 200	Abmessungen (Breite) / Dimensions (width)	220 mm
Wandabstand / Wall distance	55 - 440 mm / 55-440 mm	Abmessungen (Höhe) / Dimensions (height)	220 mm
Tragarm / Support arm	Schwenkarm mit 3 Gelenken / swivel arm with 3 hinges	Abmessungen (Tiefe) / Dimensions (depth)	55 mm
Neigbar (vertikal) / Tilttable (vertically)	-15° bis +15° / -15° bis +15°	Garantie / Guarantee	5 Jahre Gewährleistung / 5-year guarantee
Schwenkbar (horizontal) / Swivelling (horizontal)	-90° bis +90° und 180° / -90° to +90° and 180°		
Drehbar (axial) / Swivelling (axial)	360° / 360°		
Belastbarkeit / Capacity	25 kg / 25 kg		
Farbe / Colour	Schwarz / black		
Produktmaterial / Material of product	Metall pulverbeschichtet / rostfrei / metal powder-coated / stainless		
Gewicht / Weight	2,3 kg		

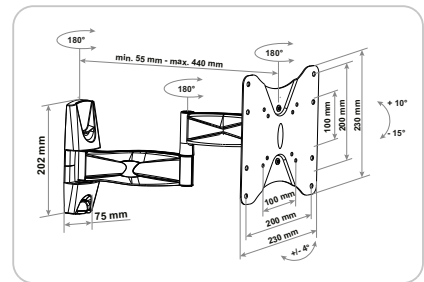

Art. Nr. / Art. No.	EAN / EAN	Verpackungsart / Packaging
LWH350 511	4004005132366	Karton carton

LWH050 011

PROFESSIONAL

TV Wandhalter (3 Gelenke) | TV Wall Mount (3 Hinges)

für Flachbildschirme (58 - 107 cm) | for Flat Screens (58 - 107 cm)



- Gelenkhalter für einen Monitor oder Flachbildschirm
- Gelenke in der Festigkeit einfach verstellbar
- Einfache Montage
- Wandabdeckung inklusive
- Kabelführung integriert
- Stabile Ausführung
- Montage nur an stabilen Wänden
- Lieferumfang: Wandhalter, Montagezubehör, Bedienungsanleitung
- hinged mount for one monitor or flat screen
- hinges can easily be tightened or loosened
- easy installation
- with wall cover
- integrated cable gland
- solid design
- installation on sturdy walls only
- content: wall mount, installation accessories, user manual



Technische Daten | Technical data

VESA Norm	75 x 75/100 x 100/200 x 200	Abmessungen (Breite) / Dimensions (width)	220 mm
VESA norm	75 x 75/100 x 100/200 x 200	Abmessungen (Höhe) / Dimensions (height)	220 mm
Wandabstand / Wall distance	476 mm / 476 mm	Abmessungen (Tiefe) / Dimensions (depth)	476 mm
Tragarm / Support arm	Schwenkarm mit 3 Gelenken / swivel arm with 3 hinges	Garantie / Guarantee	5 Jahre Gewährleistung / 5-year guarantee
Neigbar (vertikal) / Tilttable (vertically)	-20° bis +20° / -20° to +20°		
Schwenkbar (horizontal) / Swivelling (horizontal)	180° / 180°		
Belastbarkeit / Capacity	30 kg / 30 kg		
Farbe / Colour	Schwarz / black		
Produktmaterial / Material of product	Metall pulverbeschichtet / rostfrei / metal powder-coated / stainless		
Gewicht / Weight	1,9 kg / 1,9 kg		

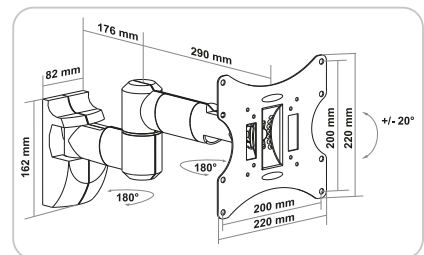

Art. Nr. / Art. No.	EAN / EAN	Verpackungsart / Packaging
LWH050 011	4004005050066	Karton carton

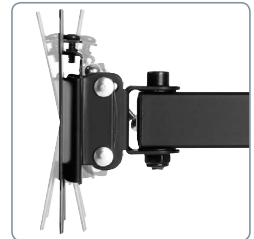
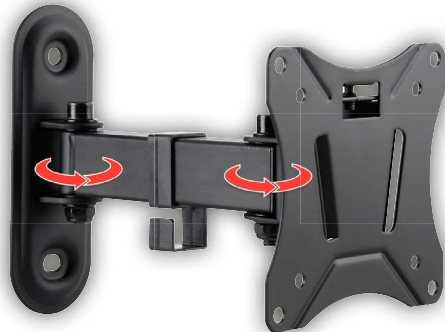

LWHS2725 513

ULTIMATE

TV Wandhalter "MOTION 2" | TV Wall Mount "MOTION 2"



für 25 kg Gewicht, neigbar, schwenkbar | for 25 kg of weight, tiltable, swivelling

- Halterung für einen Flachbildschirm (LCD, LED, TFT, Plasma)
- Ausziehbarer Doppeltragrahm für verschiedene Betrachtungswinkel
- Gelenke in der Festigkeit einfach verstellbar
- Kabelführung integriert
- Nach vorn neigbar
- Nach links und rechts schwenkbar
- Stabile Ausführung
- Einfache Installation und Handhabung
- Lieferumfang: Wandhalter, Montagezubehör, Bedienungsanleitung
- mount for a flat screen (LED, LCD, TFT or plasma screen)
- extendable double support arm for different viewing angles
- hinges can easily be tightened or loosened
- integrated cable gland
- can be tilted forward
- can be swivelling left and right
- solid design
- easy installation and handling
- content: wall mount, installation accessories, user manual

Technische Daten | Technical data

VESA Norm 75 x 75/100 x 100

VESA norm 75 x 75/100 x 100

Wandabstand 72 - 196 mm

Wall distance 72-196 mm

Neigbar (vertikal) -7,5° bis +7,5°

Tiltable (vertically) -7,5° to +7,5°

Schwenkbar (horizontal) 180°

Swivelling (horizontal) 180°

Belastbarkeit 25 kg

Capacity 25 kg

Farbe Schwarz

Colour black

Produktmaterial Aluminium pulverbeschichtet

Material of product Aluminium powder-coated

Gewicht 0,8 kg

Weight (set) 0,8 kg

Abmessungen (Breite) 115 mm

Dimensions (width) 115 mm

Abmessungen (Höhe) 150 mm

Dimensions (height) 150 mm

Abmessungen (Tiefe) 196 mm

Dimensions (depth) 196 mm

Garantie 5 Jahre Gewährleistung

Guarantee 5-year guarantee

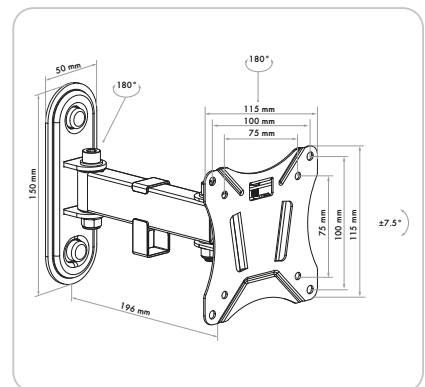

Art. Nr.

Art. No.

LWHS2725 513

EAN

EAN

4004005011562

Verpackungsart

Packaging

Karton | carton

LWH032 031



TV Wandhalter (3 Gelenke) | TV Wall Mount (3 Hinges)

für Flachbildschirme (33 – 76 cm) | for Flat Screens (33 - 76 cm)



- Gelenkhalter für einen Monitor oder Flachbildschirm
- Einfache Montage durch CLICK & SAVE System
- Kabelführung integriert
- Wasserwaage zur exakten Ausrichtung der Montageschiene integriert
- Lieferumfang: Wandhalter, Montagezubehör, Bedienungsanleitung
- hinged mount for one monitor or flat screen
- easy installation through CLICK & SAVE system
- integrated cable gland
- integrated bubble level for accurate alignment of the mounting rail
- content: wall mount, installation accessories, user manual

Technische Daten | Technical data

VESA Norm	75 x 75/100 x 100
VESA norm	75 x 75/100 x 100
Wandabstand	90 mm
Wall distance	90 mm
Tragarm	Schwenkarm mit 3 Gelenken
Support arm	swivel arm with 3 hinges
Neigbar (vertikal)	-20° bis +20°
Tilttable (vertically)	-20° to +20°
Schwenkbar (horizontal)	-90° bis +90° und -135° bis +135°
Swivelling (horizontal)	-90° bis +90° and -135° bis +135°
Belastbarkeit	18 kg
Capacity	18 kg
Farbe	Schwarz
Colour	black
Produktmaterial	Aluminium Druckguss
Material of product	aluminium die cast
Gewicht	1.22 kg
Weight (set)	1.22 kg
Abmessungen (Breite)	117 mm
Dimensions (width)	117 mm
Abmessungen (Höhe)	226 mm

Abmessungen (Tiefe)	255 mm
Dimensions (depth)	255 mm
Garantie	5 Jahre Gewährleistung
Guarantee	5-year guarantee

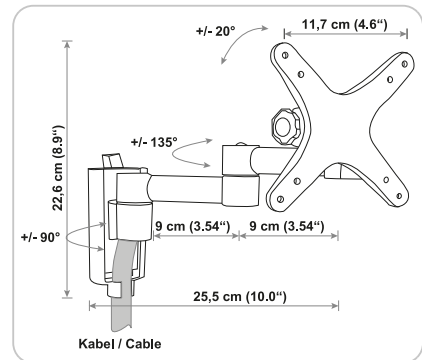

Art. Nr.	EAN	Verpackungsart
Art. No.	EAN	Packaging
LWH032 031	4004005032024	Schweißblister SF sealed blister SF

LWH031 031



TV Wandhalter (2 Gelenke) | TV Wall Mount (2 Hinges)

für Flachbildschirme (33 – 76 cm) | for Flat Screens (33 - 76 cm)

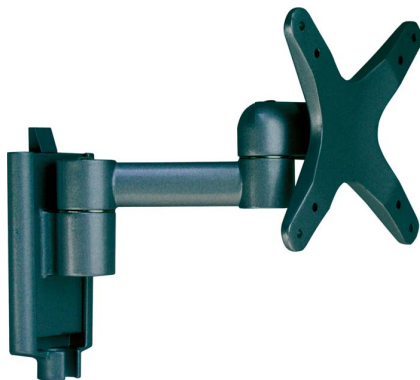

- Gelenkhalter für einen Monitor oder Flachbildschirm
- Gelenke in der Festigkeit einfach verstellbar
- Kabelführung integriert
- Wasserwaage zur exakten Ausrichtung der Montageschiene integriert
- Einfache Montage durch CLICK & SAVE System
- Lieferumfang: Wandhalter, Montagezubehör, Bedienungsanleitung
- hinged mount for one monitor or flat screen
- hinges can easily be tightened or loosened
- integrated cable gland
- integrated bubble level for accurate alignment of the mounting rail
- easy installation through CLICK & SAVE system
- content: wall mount, installation accessories, user manual

Technische Daten | Technical data

VESA Norm	75 x 75/100 x 100
VESA norm	75 x 75/100 x 100
Wandabstand	90 mm
Wall distance	90 mm
Tragarm	Schwenkarm mit 2 Gelenken
Support arm	swivel arm with 2 hinges
Neigbar (vertikal)	-20° bis +20°
Tilttable (vertically)	-20° to +20°
Schwenkbar (horizontal)	-90° bis +90°
Swivelling (horizontal)	-90° bis +90°
Belastbarkeit	18 kg
Capacity	18 kg
Farbe	Schwarz
Colour	black
Produktmaterial	Aluminium Druckguss
Material of product	aluminium die cast
Gewicht	1.04 kg
Weight (set)	1.04 kg
Abmessungen (Breite)	173 mm
Dimensions (width)	173 mm
Abmessungen (Höhe)	201 mm
Dimensions (height)	201 mm

Abmessungen (Tiefe)	165 mm
Dimensions (depth)	165 mm
Garantie	5 Jahre Gewährleistung
Guarantee	5-year guarantee

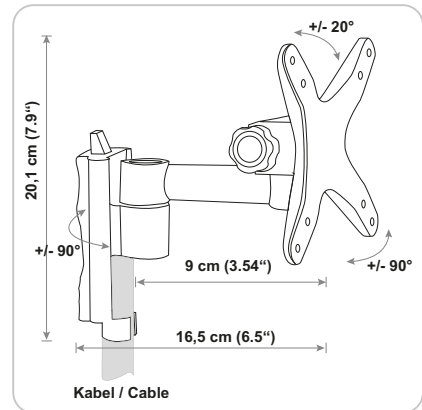

Art. Nr.	EAN	Verpackungsart
Art. No.	EAN	Packaging
LWH031 031	4004005031027	Schweißblister SF sealed blister SF

LWH240 511

ULTIMATE

TV Wandhalter (2 Gelenke) | TV Wall Mount (2 Hinges)

für Flachbildschirme (58 - 107 cm) | for Flat Screens (58 - 107 cm)



- Stabile Ausführung
- Halterung für einen Flachbildschirm (LCD, LED, TFT, Plasma)
- Kabelführung integriert
- Einfache Montage durch CLICK & SAVE System
- Montageplatte drehbar
- Lieferumfang: Wandhalter, Montagezubehör, Bedienungsanleitung
- solid design
- mount for a flat screen (LED, LCD, TFT or plasma screen)
- integrated cable gland
- easy installation through CLICK & SAVE system
- rotating mounting plate
- content: wall mount, installation accessories, user manual

Technische Daten | Technical data

VESA Norm	75 x 75/100 x 100/200 x 100/200 x 200
VESA norm	75 x 75/100 x 100/200 x 100/200 x 200
Wandabstand Wall distance	55 - 280 mm 55-280 mm
Tragarm Support arm	Schwenkarm mit 2 Gelenken swivel arm with 2 hinges
Neigbar (vertikal) Tiltable (vertically)	-15° bis +15° -15° bis +15°
Schwenkbar (horizontal) Swivelling (horizontal)	-90° bis +90° -90° bis +90°
Drehbar (axial) Swivelling (axial)	360° 360°
Belastbarkeit Capacity	25 kg 25 kg
Farbe Colour	Schwarz black
Produktmaterial Material of product	Metall pulverbeschichtet rostfrei metal powder-coated rust-free

	stainless
Gewicht Weight (set)	1,7 kg 1,7 kg
Abmessungen (Breite) Dimensions (width)	220 mm 220 mm
Abmessungen (Höhe) Dimensions (height)	220 mm 220 mm
Abmessungen (Tiefe) Dimensions (depth)	280 mm 280 mm

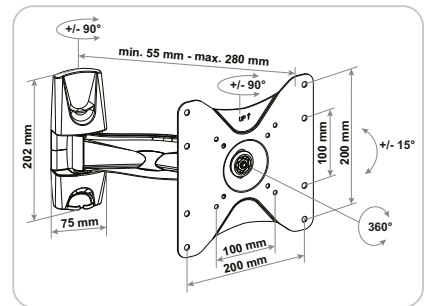

Art. Nr. Art. No.	EAN EAN	Verpackungsart Packaging
LWH240 511	4004005132359	Karton carton

LWH040 011

PROFESSIONAL

TV Wandhalter (2 Gelenke) | TV Wall Mount (2 Hinges)

für Flachbildschirme (58 - 107 cm) | for Flat Screens (58 - 107 cm)

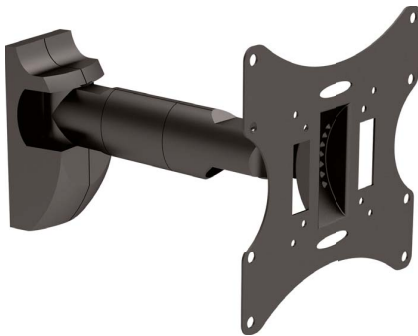

- Einfache Montage
- Gelenke in der Festigkeit einfach verstellbar
- Gelenkhalter für einen Monitor oder Flachbildschirm
- Wandabdeckung inklusive
- Kabelführung integriert
- Montage nur an stabilen Wänden
- Stabile Ausführung
- Lieferumfang: Wandhalter, Montagezubehör, Bedienungsanleitung
- easy installation
- hinges can easily be tightened or loosened
- hinged mount for one monitor or flat screen
- with wall cover
- integrated cable gland
- installation on sturdy walls only
- solid design
- content: wall mount, installation accessories, user manual

Technische Daten | Technical data

VESA Norm	75 x 75/100 x 100/200 x 200
VESA norm	75 x 75/100 x 100/200 x 200
Wandabstand Wall distance	330 mm 330 mm
Tragarm Support arm	Schwenkarm mit 2 Gelenken swivel arm with 2 hinges
Neigbar (vertikal) Tiltable (vertically)	-20° bis +20° -20° to +20°
Schwenkbar (horizontal) Swivelling (horizontal)	2x 180° 2x 180°
Belastbarkeit Capacity	30 kg 30 kg
Farbe Colour	Schwarz black
Produktmaterial Material of product	Metall pulverbeschichtet rostfrei metal powder-coated stainless
Gewicht Weight (set)	1,5 kg 1,5 kg

Abmessungen (Breite) Dimensions (width)	220 mm 220 mm
Abmessungen (Höhe) Dimensions (height)	220 mm 220 mm
Abmessungen (Tiefe) Dimensions (depth)	330 mm 330 mm
Garantie Guarantee	5 Jahre Gewährleistung 5-year guarantee

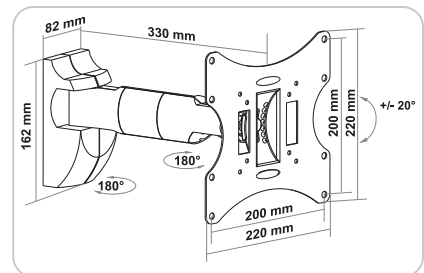

Art. Nr. Art. No.	EAN EAN	Verpackungsart Packaging
LWH040 011	4004005040227	Karton carton



LWH130 511

ULTIMATE

TV Wandhalter (1 Gelenk) | TV Wall Mount (1 Hinge)

für Flachbildschirme (58 - 107 cm) | for Flat Screens (58 - 107 cm)



- Montage nur an stabilen Wänden/Decken
- Stabile Ausführung
- Halterung für einen Flachbildschirm (LCD, LED, TFT, Plasma)
- Einfache Montage durch CLICK & SAVE System
- Lieferumfang: Wandhalter, Montagezubehör, Bedienungsanleitung
- for installation on sturdy walls / ceilings only
- solid design
- mount for a flat screen (LED, LCD, TFT or plasma screen)
- easy installation through CLICK & SAVE system
- content: wall mount, installation accessories, user manual

Technische Daten | Technical data

VESA Norm	75 x 75/100 x 100/200 x 100/200 x 200	Garantie	5 Jahre Gewährleistung
VESA norm	75 x 75/100 x 100/200 x 100/200 x 200	Guarantee	5-year guarantee
Wandabstand	61 mm		
Wall distance	61 mm		
Tragarm	Schwenkarm mit 1 Gelenk		
Support arm	swivel arm with 1 hinge		
Neigbar (vertikal)	-10° bis +15°		
Tiltable (vertically)	-10° to +15°		
Schwenkbar (horizontal)	50°		
Swivelling (horizontal)	50°		
Drehbar (axial)	-4° bis +4°		
Swivelling (axial)	-4° to +4°		
Belastbarkeit	25 kg		
Capacity	25 kg		
Farbe	Schwarz		
Colour	black		
Gewicht	1,4 kg		
Weight (set)	1,4 kg		
Abmessungen (Breite)	230 mm		
Dimensions (width)	230 mm		
Abmessungen (Höhe)	230 mm		
Dimensions (height)	230 mm		
Abmessungen (Tiefe)	61 mm		
Dimensions (depth)	61 mm		

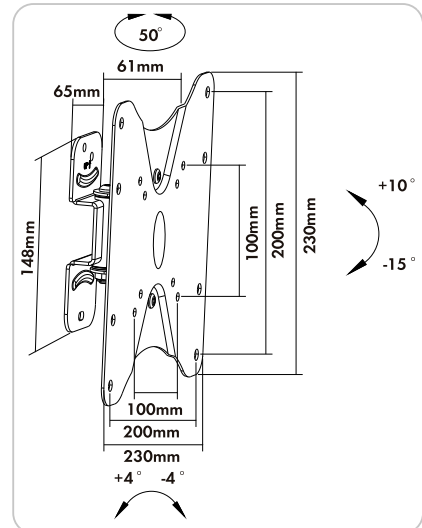

Art. Nr.	EAN	Verpackungsart
Art. No.	EAN	Packaging
LWH130 511	4004005132342	Karton carton



LWH14225 513

ULTIMATE

TV Wandhalter "MOTION 1" | TV Wall Mount "MOTION 1"



für 25 kg Gewicht, neigbar, schwenkbar | for 25 kg of weight, tiltable, swiveling

- Halterung für einen Flachbildschirm (LCD, LED, TFT, Plasma)
- Gelenke in der Festigkeit einfach verstellbar
- Nach vorn neigbar
- Nach links und rechts schwenkbar
- Stabile Ausführung
- Einfache Installation und Handhabung
- Lieferumfang: Wandhalter, Montagezubehör, Bedienungsanleitung
- mount for a flat screen (LED, LCD, TFT or plasma screen)
- hinges can easily be tightened or loosened
- can be tilted forward
- can be swivelling left and right
- solid design
- easy installation and handling
- content: wall mount, installation accessories, user manual



Technische Daten | Technical data

VESA Norm	75 x 75/100 x 100/200 x 100/200 x 200
VESA norm	75 x 75/100 x 100/200 x 100/200 x 200
Wandabstand Wall distance	76 mm 76 mm
Neigbar (vertikal) Tiltable (vertically)	+7,5° bis -7,5° +7,5° to -7,5°
Schwenkbar (horizontal) Swivelling (horizontal)	+25° bis -25° +25° to -25°
Belastbarkeit Capacity	25 kg 25 kg
Produktmaterial Material of product	Aluminium pulverbeschichtet Aluminium powder-coated
Gewicht Weight (set)	1,1 kg 1,1 kg
Abmessungen (Breite) Dimensions (width)	240 mm 240 mm
Abmessungen (Höhe) Dimensions (height)	240 mm 240 mm
Abmessungen (Tiefe) Dimensions (depth)	76 mm 76 mm

Dimensions (depth)	76 mm
Garantie Guarantee	5 Jahre Gewährleistung 5-year guarantee

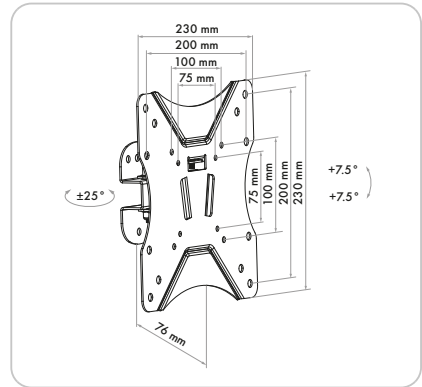

Art. Nr. Art. No.	EAN EAN	Verpackungsart Packaging
LWH14225 513	4004005011579	Karton carton

LWH030 011



TV Wandhalter (1 Gelenk) | TV Wall Mount (1 Hinge)

für Flachbildschirme (58 - 107 cm) | for Flat Screens (58 - 107 cm)



- Einfache Montage
- Gelenke in der Festigkeit einfach verstellbar
- Gelenkhalter für einen Monitor oder Flachbildschirm
- Stabile Ausführung
- Montage nur an stabilen Wänden
- Lieferumfang: Wandhalter, Montagezubehör, Bedienungsanleitung
- easy installation
- hinges can easily be tightened or loosened
- hinged mount for one monitor or flat screen
- solid design
- installation on sturdy walls only
- content: wall mount, installation accessories, user manual

Technische Daten | Technical data

VESA Norm	75 x 75/100 x 100/200 x 100/200 x 200
VESA norm	75 x 75/100 x 100/200 x 100/200 x 200
Wandabstand Wall distance	90 mm
Tragarm Support arm	Schwenkarm mit 1 Gelenk swivel arm with 1 hinge
Neigbar (vertikal) Tiltable (vertically)	-20° bis +20° -20° to +20°
Schwenkbar (horizontal) Swivelling (horizontal)	60° 60°
Belastbarkeit Capacity	30 kg 30 kg
Farbe Colour	Schwarz black
Produktmaterial Material of product	Metall pulverbeschichtet rostfrei metal powder-coated stainless
Gewicht Weight (set)	0,9 kg 0,9 kg
Abmessungen (Breite) Dimensions (width)	220 mm 220 mm
Abmessungen (Höhe) Dimensions (height)	220 mm

Abmessungen (Tiefe) Dimensions (depth)	90 mm 90 mm
Garantie Guarantee	5 Jahre Gewährleistung 5-year guarantee

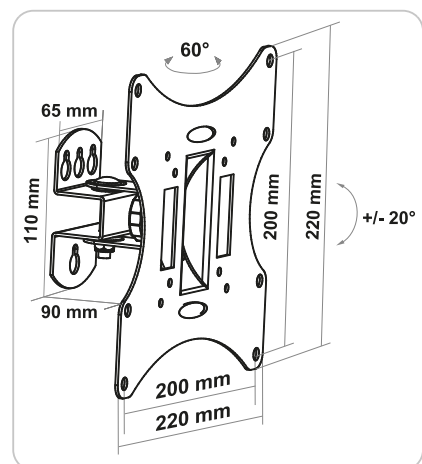

Art. Nr. Art. No.	EAN EAN	Verpackungsart Packaging
LWH030 011	4004005030068	Karton carton

LWHT2725 513



TV Wandhalter "TILT 1" | TV Wall Mount "TILT 1"

für 25 kg Gewicht, neigbar | 25 kg of weight, tiltable



- Einfache Montage
- Nach vorn neigbar
- Gelenke in der Festigkeit einfach verstellbar
- Stabile Ausführung
- Montage nur an stabilen Wänden
- Lieferumfang: Wandhalter, Montagezubehör, Bedienungsanleitung
- easy installation
- can be tilted forward
- hinges can easily be tightened or loosened
- solid design
- installation on sturdy walls only
- content: wall mount, installation accessories, user manual

Technische Daten | Technical data

VESA Norm	75 x 75/100 x 100
VESA norm	75 x 75/100 x 100
Wandabstand Wall distance	34 mm 34 mm
Neigbar (vertikal) Tiltable (vertically)	+3° bis -12° +3° to -12°
Belastbarkeit Capacity	25 kg 25 kg
Farbe Colour	Schwarz black
Produktmaterial Material of product	Metall pulverbeschichtet rostfrei metal powder-coated stainless
Gewicht Weight (set)	0,4 kg 0,4 kg
Abmessungen (Breite) Dimensions (width)	115 mm 115 mm
Abmessungen (Höhe) Dimensions (height)	115 mm 115 mm
Abmessungen (Tiefe) Dimensions (depth)	34 mm

Abmessungen (Tiefe) Dimensions (depth)	34 mm
Garantie Guarantee	5 Jahre Gewährleistung 5-year guarantee

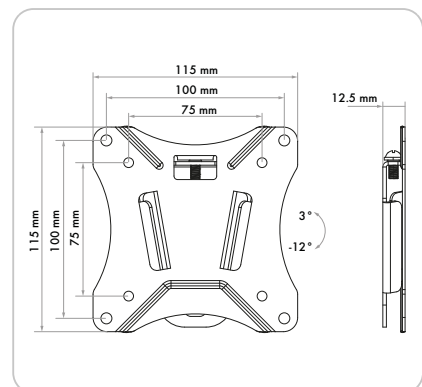

Art. Nr. Art. No.	EAN EAN	Verpackungsart Packaging
LWHT2725 513	4004005011555	Karton carton

LWH7075 511

PROFESSIONAL

TV Wandhalter | TV Wall Mounts

für Flachbildschirme (94 - 178 cm) | for Flat Screens (94 - 178 cm)

- Halterung für einen Flachbildschirm (LCD, LED, TFT, Plasma)
- Nach vorn neigbar
- Einfache Montage
- Hohe mechanische Belastbarkeit
- Wasserwaage zur exakten Ausrichtung der Montagesechiene integriert
- Montage nur an stabilen Wänden
- Lieferumfang: Wandhalter, Montagezubehör, Bedienungsanleitung
- mount for a flat screen (LED, LCD, TFT or plasma screen)
- can be tilted forward
- easy installation
- high mechanical resilience
- integrated bubble level for accurate alignment of the mounting rail
- installation on sturdy walls only
- content: wall mount, installation accessories, user manual

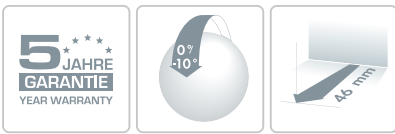

Technische Daten | Technical data

VESA Norm	max. 800
VESA norm	max. 800
Wandabstand	46 mm
Wall distance	46 mm
Neigbar (vertikal)	0° bis -10°
Tilttable (vertically)	0° bis -10°
Belastbarkeit	75 kg
Capacity	75 kg
Farbe	Schwarz
Colour	black
Produktmaterial	Metall pulverbeschichtet
Material of product	metal powder-coated
	rostfrei
	stainless
Gewicht	3,3 kg
Weight (set)	3,3 kg
Abmessungen (Breite)	885 mm
Dimensions (width)	885 mm
Abmessungen (Höhe)	225 mm

Dimensions (height)	225 mm
Abmessungen (Tiefe)	60 mm
Dimensions (depth)	60 mm
Garantie	5 Jahre Gewährleistung
Guarantee	5-year guarantee

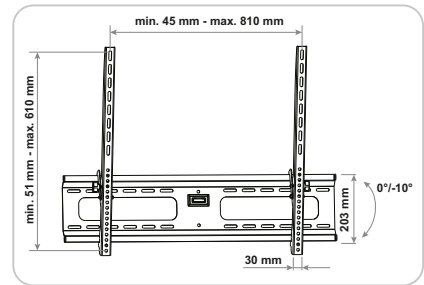

Art. Nr.	EAN	Verpackungsart
Art. No.	EAN	Packaging
LWH7075 511	4004005132335	Karton carton

LWHT7050 513

PROFESSIONAL

TV Wandhalter "TILT 3" | TV Wall Mount "TILT 3"

für 50 kg Gewicht, neigbar | 25 kg of weight, tiltable

- Halterung für einen Flachbildschirm (LCD, LED, TFT, Plasma)
- Montage nur an stabilen Wänden
- Einfache Installation und Handhabung
- Nach vorn neigbar
- Stabile Ausführung
- Lieferumfang: Wandhalter, Montagezubehör, Bedienungsanleitung
- mount for a flat screen (LED, LCD, TFT or plasma screen)
- installation on sturdy walls only
- easy installation and handling
- can be tilted forward
- solid design
- content: wall mount, installation accessories, user manual



Technische Daten | Technical data

VESA Norm	200 x 200/300 x 300/400 x 200/400
VESA norm	200 x 200/300 x 300/400 x 200/400
Wandabstand	56 mm
Wall distance	56 mm
Neigbar (vertikal)	+5° bis -10°
Tilttable (vertically)	+5° to -10°
Belastbarkeit	50 kg
Capacity	50 kg
Farbe	Schwarz
Colour	black
Produktmaterial	Metall pulverbeschichtet
Material of product	metal powder-coated
	rostfrei
	stainless
Gewicht	2,3 kg
Weight (set)	2,3 kg
Abmessungen (Breite)	653 mm
Dimensions (width)	653 mm

Abmessungen (Höhe)	425 mm
Dimensions (height)	425 mm
Abmessungen (Tiefe)	56 mm
Dimensions (depth)	56 mm
Garantie	5 Jahre Gewährleistung
Guarantee	5-year guarantee

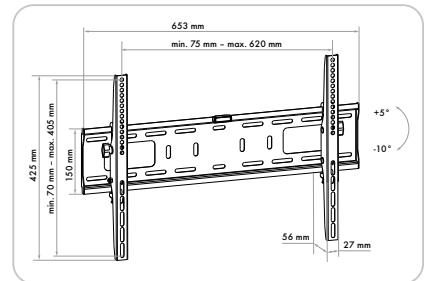

Art. Nr.	EAN	Verpackungsart
Art. No.	EAN	Packaging
LWHT7050 513	4004005010695	Karton carton

LWHT5535 513



TV Wandhalter "TILT 2" | TV Wall Mount "TILT 2"

für 35 kg Gewicht, neigbar | 35 kg of weight, tiltable

- Halterung für einen Flachbildschirm (LCD, LED, TFT, Plasma)
 - Einfache Installation und Handhabung
 - Zugschlaufen zur Entriegelung des Gerätes vom Halter
 - Nach vorn neigbar
 - Montage nur an stabilen Wänden
 - Stabile Ausführung
 - Lieferumfang: Wandhalter, Montagezubehör, Bedienungsanleitung
- mount for a flat screen (LED, LCD, TFT or plasma screen)
 - easy installation and handling
 - Pull loops for unlocking of the device from the holder
 - can be tilted forward
 - installation on sturdy walls only
 - solid design
 - content: wall mount, installation accessories, user manual



Technische Daten | Technical data

VESA Norm	200 x 200/300 x 300/400 x 200/400 x 400
VESA norm	200 x 200/300 x 300/400 x 200/400 x 400
Wandabstand	20,5 mm
Wall distance	20.5 mm
Neigbar (vertikal)	+0° bis -8°
Tiltable (vertically)	+3° to -12°
Belastbarkeit	35 kg
Capacity	35 kg
Produktmaterial	Metall pulverbeschichtet
Material of product	metal powder-coated
	rostfrei
	stainless
Gewicht	1,1 kg
Weight (set)	1,1 kg
Abmessungen (Breite)	465 mm
Dimensions (width)	465 mm
Abmessungen (Höhe)	422 mm
Dimensions (height)	422 mm
Abmessungen (Tiefe)	20,5 mm

Dimensions (depth)	20,5 mm
Garantie	5 Jahre Gewährleistung
Guarantee	5-year guarantee

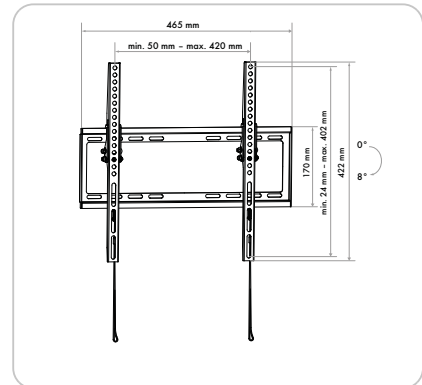

Art. Nr.	EAN	Verpackungsart
Art. No.	EAN	Packaging
LWHT5535 513	4004005010893	Karton carton

LWH4275 511



TV Wandhalter | TV Wall Mounts

für Flachbildschirme (81 - 140 cm) | for flat screens (81 - 140 cm)

- Einfache Montage
 - Wasserwaage zur exakten Ausrichtung der Montageschiene integriert
 - Hohe mechanische Belastbarkeit
 - Nach vorn neigbar
 - Montage nur an stabilen Wänden
 - Lieferumfang: Wandhalter, Montagezubehör, Bedienungsanleitung
- easy installation
 - integrated bubble level for accurate alignment of the mounting rail
 - high mechanical resilience
 - can be tilted forward
 - installation on sturdy walls only
 - content: wall mount, installation accessories, user manual

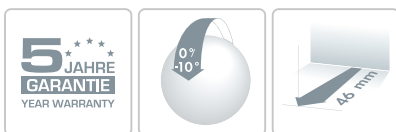

Technische Daten | Technical data

VESA Norm	400 x 400
VESA norm	400 x 400
Wandabstand	46 mm
Wall distance	46 mm
Tragarm	horizontal verstellbar
Support arm	horizontally adjustable
Neigbar (vertikal)	-10° bis 0°
Tiltable (vertically)	-10° bis 0°
Belastbarkeit	75 kg
Capacity	75 kg
Farbe	Schwarz
Colour	black
Produktmaterial	Metall pulverbeschichtet
Material of product	metal powder-coated
	rostfrei
	stainless
Gewicht	2,5 kg
Weight (set)	2,5 kg
Abmessungen (Breite)	475 mm
Dimensions (width)	475 mm
Abmessungen (Höhe)	225 mm

Dimensions (height)	225 mm
Abmessungen (Tiefe)	60 mm
Dimensions (depth)	60 mm
Garantie	5 Jahre Gewährleistung
Guarantee	5-year guarantee

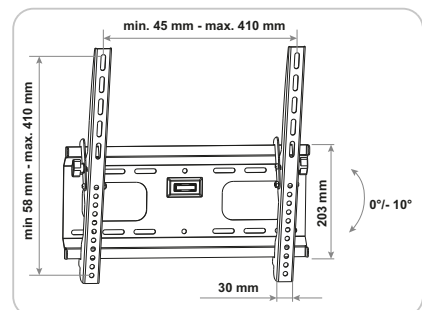

Art. Nr.	EAN	Verpackungsart
Art. No.	EAN	Packaging
LWH4275 511	4004005132328	Karton carton

LWHF8035 513

☆☆☆
STANDARD

TV Wandhalter "FIXED 3" | TV Wall Mount "FIXED 3"

für 45 kg Gewicht, fix | for 45 kg of weight, fix

- Halterung für einen Flachbildschirm (LCD, LED, TFT, Plasma) • *mount for a flat screen (LED, LCD, TFT or plasma screen)*
- Einfache Montage • *easy installation*
- Hohe mechanische Belastbarkeit • *high mechanical resilience*
- Montage nur an stabilen Wänden • *installation on sturdy walls only*
- Lieferumfang: Wandhalter, Montagezubehör, Bedienungsanleitung • *content: wall mount, installation accessories, user manual*

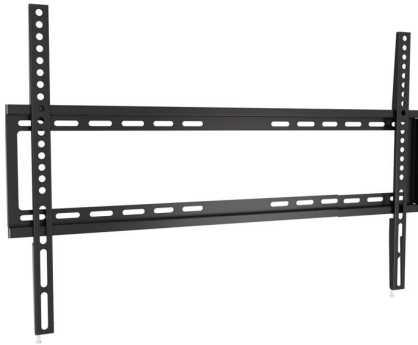

Technische Daten | Technical data

VESA Norm 200 x 200/300 x 300/400 x 200/400 x 400/600 x 400
 VESA norm 200 x 200/300 x 300/400 x 200/400 x 400/600 x 400

Dimensions (depth) 19,5 mm

Wandabstand 19,5 mm
 Wall distance 19,5 mm

Belastbarkeit 45 kg
 Capacity 45 kg

Gewicht 1,2 kg
 Weight (set) 1,2 kg

Abmessungen (Breite) 665 mm
 Dimensions (width) 665 mm

Abmessungen (Höhe) 422 mm
 Dimensions (height) 422 mm

Abmessungen (Tiefe) 19,5 mm

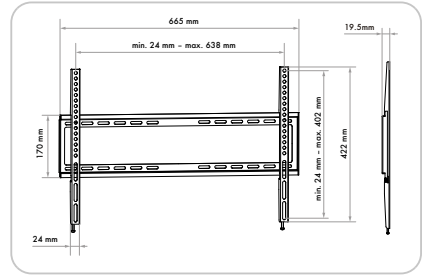

Art. Nr. Art. No.	EAN EAN	Verpackungsart Packaging
LWHF8035 513	4004005012194	Karton carton

LWHF5535 513

☆☆☆
STANDARD

TV Wandhalter "FIXED 2" | TV Wall Mount "FIXED 2"

für 35 kg Gewicht, fix | for 35 kg of weight, fix

- Halterung für einen Flachbildschirm (LCD, LED, TFT, Plasma) • *mount for a flat screen (LED, LCD, TFT or plasma screen)*
- Einfache Montage • *easy installation*
- Hohe mechanische Belastbarkeit • *high mechanical resilience*
- Montage nur an stabilen Wänden • *installation on sturdy walls only*
- Lieferumfang: Wandhalter, Montagezubehör, Bedienungsanleitung • *content: wall mount, installation accessories, user manual*



Technische Daten | Technical data

VESA Norm 200 x 300/300 x 300/400 x 200/400 x 400
 VESA norm 200 x 300/300 x 300/400 x 200/400 x 400

Wandabstand 19,5 mm
 Wall distance 19,5 mm

Belastbarkeit 35 kg
 Capacity 35 kg

Gewicht 1 kg
 Weight (set) 1 kg

Abmessungen (Breite) 115 mm
 Dimensions (width) 115 mm

Abmessungen (Höhe) 115 mm
 Dimensions (height) 115 mm

Abmessungen (Tiefe) 12,5 mm
 Dimensions (depth) 12,5 mm

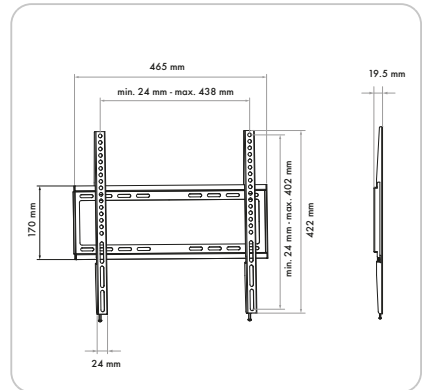

Art. Nr. Art. No.	EAN EAN	Verpackungsart Packaging
LWHF5535 513	4004005012187	Karton carton

LWH3263 011

★★★
STANDARD

TV Wandhalter (fix) | TV Wall Mount (fixed)

für Flachbildschirme (107 - 178 cm) | for flat screens (107 - 178 cm)

- Halterung für einen Flachbildschirm (LCD, LED, TFT, Plasma)
- Mechanisch stabil
- Stabile Ausführung
- Wasserwaage zur exakten Ausrichtung der Montagesschiene integriert
- Montage nur an stabilen Wänden/Decken
- Lieferumfang: Wandhalter, Montagezubehör, Bedienungsanleitung
- mount for a flat screen (LED, LCD, TFT or plasma screen)
- mechanically solid
- solid design
- integrated bubble level for accurate alignment of the mounting rail
- for installation on sturdy walls / ceilings only
- content: wall mount, installation accessories, user manual



Technische Daten | Technical data

VESA Norm	max. 800	Dimensions (height)	60 mm
VESA norm	max. 800	Abmessungen (Tiefe)	20 mm
Wandabstand	14,5 mm	Dimensions (depth)	20 mm
Wall distance	14.5 mm	Garantie	5 Jahre Gewährleistung
Belastbarkeit	50 kg	Guarantee	5-year guarantee
Capacity	50 kg		
Farbe	Schwarz		
Colour	black		
Produktmaterial	Metall pulverbeschichtet		
Material of product	rostfrei		
	metal powder-coated		
	stainless		
Gewicht	1.4 kg		
Weight (set)	1.4 kg		
Abmessungen (Breite)	800 mm		
Dimensions (width)	800 mm		
Abmessungen (Höhe)	60 mm		

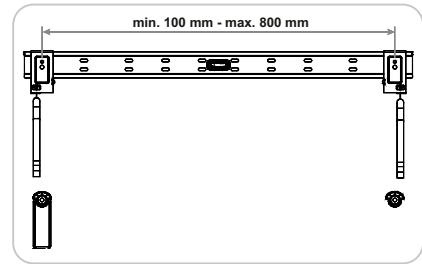

Art. Nr.	EAN	Verpackungsart
Art. No.	EAN	Packaging
LWH3263 011	4004005326307	Karton carton

LWH2337 011

★★★
STANDARD

TV Wandhalter (fix) | TV Wall Mount (fixed)

für Flachbildschirme (81 - 140 cm) | for flat screens (81 - 140 cm)

- Halterung für einen Flachbildschirm (LCD, LED, TFT, Plasma)
- Klappbarer Wandabstandsbügel für besseren Zugang zu den Geräteanschlüssen
- Mechanisch stabil
- Stabile Ausführung
- Wasserwaage zur exakten Ausrichtung der Montagesschiene integriert
- Montage nur an stabilen Wänden
- Lieferumfang: Wandhalter, Montagezubehör, Bedienungsanleitung
- mount for a flat screen (LED, LCD, TFT or plasma screen)
- hinged wall distancing bracket for easier access to the connections of the device
- mechanically solid
- solid design
- integrated bubble level for accurate alignment of the mounting rail
- installation on sturdy walls only
- content: wall mount, installation accessories, user manual



Technische Daten | Technical data

VESA Norm	max. 400	Dimensions (height)	60 mm
VESA norm	max. 400	Abmessungen (Tiefe)	14,5 mm
Wandabstand	14,5 mm	Dimensions (depth)	14.5 mm
Wall distance	14.5 mm	Garantie	5 Jahre Gewährleistung
Belastbarkeit	50 kg	Guarantee	5-year guarantee
Capacity	50 kg		
Farbe	Schwarz		
Colour	black		
Gewicht	1.2 kg		
Weight (set)	1.2 kg		
Abmessungen (Breite)	485 mm		
Dimensions (width)	485 mm		
Abmessungen (Höhe)	60 mm		
Dimensions (height)	60 mm		

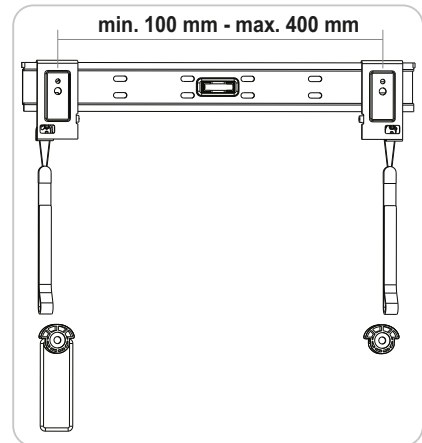

Art. Nr.	EAN	Verpackungsart
Art. No.	EAN	Packaging
LWH2337 011	4004005324204	Karton carton

LWHF2725 513

☆☆☆
STANDARD

TV Wandhalter "FIXED 1" | TV Wall Mount "FIXED 1"

für 25 kg Gewicht, fix | for 25 kg of weight, fix



- Halterung für einen Flachbildschirm (LCD, LED, TFT, Plasma)
- Einfache Montage
- Hohe mechanische Belastbarkeit
- Montage nur an stabilen Wänden
- Lieferumfang: Wandhalter, Montagezubehör, Bedienungsanleitung
- mount for a flat screen (LED, LCD, TFT or plasma screen)
- easy installation
- high mechanical resilience
- installation on sturdy walls only
- content: wall mount, installation accessories, user manual

Technische Daten | Technical data

VESA Norm	75 x 75/100 x 100
VESA norm	75 x 75/100 x 100
Wandabstand	12,5 mm
Wall distance	12.5 mm
Belastbarkeit	25 kg
Capacity	25 kg
Gewicht	0,3 kg
Weight (set)	0,3 kg
Abmessungen (Breite)	115 mm
Dimensions (width)	115 mm
Abmessungen (Höhe)	115 mm
Dimensions (height)	115 mm
Abmessungen (Tiefe)	12,5 mm
Dimensions (depth)	12.5 mm

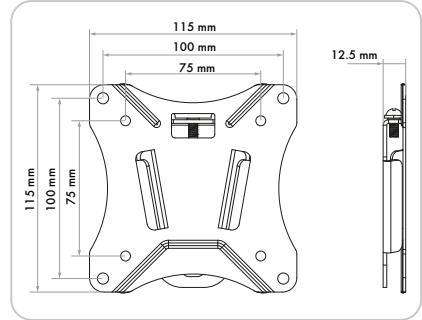

Art. Nr.	EAN	Verpackungsart
Art. No.	EAN	Packaging
LWHF2725 513	4004005011548	Karton carton

LWH1323 511

☆☆☆
STANDARD

TV Wandhalter (fix) | TV Wall Mount (fixed)

für Flachbildschirme (33 - 69 cm) | for LED Flat Screens (33-69 cm)



- Halterung für Flachbildschirme (LCD, LED, TFT, Plasma)
- Hohe mechanische Belastbarkeit
- Stabile Ausführung
- Montage nur an stabilen Wänden
- Lieferumfang: Wandhalter, Montagezubehör, Bedienungsanleitung
- mount for flat screens (LCD, LED, TFT, Plasma)
- high mechanical resilience
- solid design
- installation on sturdy walls only
- content: wall mount, installation accessories, user manual

Technische Daten | Technical data

VESA Norm	50 x 50/75 x 75/100 x 100
VESA norm	50 x 50/75 x 75/100 x 100
Wandabstand	15 mm
Wall distance	15 mm
Belastbarkeit	30 kg
Capacity	30 kg
Farbe	Schwarz
Colour	black
Produktmaterial	Metall pulverbeschichtet
Material of product	metal powder-coated
	rostfrei
	stainless
Gewicht	0,6 kg
Weight (set)	0.6 kg
Abmessungen (Breite)	140 mm
Dimensions (width)	140 mm
Abmessungen (Höhe)	120 mm
Dimensions (height)	120 mm
Abmessungen (Tiefe)	20 mm
Dimensions (depth)	20 mm

Garantie	5 Jahre Gewährleistung
Guarantee	5-year guarantee

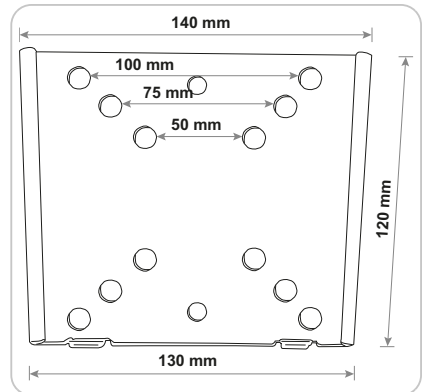

Art. Nr.	EAN	Verpackungsart
Art. No.	EAN	Packaging
LWH1323 511	4004005132304	Karton carton

LWH1737 511

★★★
STANDARD

TV Wandhalter (fix) | TV Wall Mount (fixed)

für Flachbildschirme (33 - 178 cm) | for flat screens (33 - 178 cm)



- Halterung für einen Flachbildschirm (LCD, LED, TFT, Plasma)
 - Universelle Befestigungsmöglichkeit für alle großen Bildschirme
 - VESA unabhängig
 - Stabile Ausführung
 - Hohe mechanische Belastbarkeit
 - Montage nur an stabilen Wänden
 - Zubehör: Montageanleitung und -zubehör
 - Lieferumfang: 2x Wandhalter, Montageanleitung und -zubehör
- mount for a flat screen (LED, LCD, TFT or plasma screen)
 - universal mounting possibilities for all large screens
 - independent of VESA
 - solid design
 - high mechanical resilience
 - installation on sturdy walls only
 - accessories: assembly instructions and fittings
 - content: 2x wall mount, installation instructions and accessories

Technische Daten | Technical data

VESA Norm	max. 800
VESA norm	max. 800
Wandabstand	14,5 mm
Wall distance	14.5 mm
Belastbarkeit	50 kg
Capacity	50 kg
Farbe	Schwarz
Colour	black
Produktmaterial	Metall
Material of product	Kunststoff
	metal
	plastic
Gewicht	0.3 kg
Weight (set)	0.3 kg
Abmessungen (Breite)	205 mm
Dimensions (width)	205 mm
Abmessungen (Höhe)	135 mm
Dimensions (height)	135 mm
Abmessungen (Tiefe)	40 mm
Dimensions (depth)	40 mm
Garantie	5 Jahre Gewährleistung

Guarantee 5-year guarantee

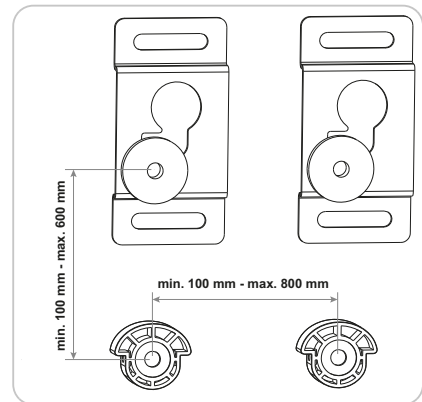

Art. Nr.	EAN	Verpackungsart
Art. No.	EAN	Packaging
LWH1737 511	4004005132311	Karton carton

LWH310WD

★★★
ULTIMATE

Wand- und Deckenhalter "BEAMER" | Wall and ceiling mount "BEAMER"

für Projektoren und Beamer | for projectors and beamers



- Halterung zur Wand- und Deckenmontage
 - Optimale Ausrichtung des Beamers/Projektors durch Neigung und Schwenkung
 - Nach vorn neigbar
 - Nach links und rechts schwenkbar
 - Montage nur an stabilen Wänden/Decken
 - Hohe mechanische Belastbarkeit
 - Lieferumfang: Beamerhalterung, Montageanleitung und -zubehör
- Bracket for wall and ceiling installation
 - optimal alignment of the projector by tilting and swivelling
 - can be tilted forward
 - can be swivelling left and right
 - for installation on sturdy walls / ceilings only
 - high mechanical resilience
 - content: projector mount, installation instructions and accessories

Technische Daten | Technical data

mittlerer Lochabstand	180 - 320 mm
middle hole spacing	180 - 320 mm
Wandabstand	350 - 560 mm
Wall distance	350-560 mm
Deckenabstand	430 - 650 mm
ceiling distance	430-650 mm
Neigbar (vertikal)	+15° bis -15°
Tiltable (vertically)	+15° to -15°
Drehbar (axial)	+8° bis -8°
Swivelling (axial)	+8° to -8°
Belastbarkeit	20 kg
Capacity	20 kg
Farbe	Weiß
Colour	white
Produktmaterial	Stahl pulverbeschichtet
Material of product	Steel powder-coated
Gewicht	1,6 kg
Weight (set)	1,6 kg

Abmessungen (Breite)	320 mm
Dimensions (width)	320 mm
Abmessungen (Höhe)	110 mm
Dimensions (height)	110 mm
Abmessungen (Tiefe)	60 mm
Dimensions (depth)	60 mm

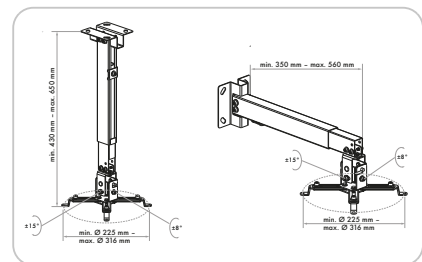

Art. Nr.	EAN	Verpackungsart
Art. No.	EAN	Packaging
LWH310WD	4004005011654	Karton carton

LWH210WD 511

ULTIMATE

Beamerhalterung | Projector Mount

für Decken- und Wandmontage | for ceiling and wall mounting

- Hohe mechanische Belastbarkeit
- Montage nur an stabilen Wänden/Decken
- Universelle Befestigungsmöglichkeit für alle Beamer an den Gewindebuchsen mit einem Abstand von 180 bis 320 mm
- Lieferumfang: Beamerhalterung, Montageanleitung und -zubehör

- high mechanical resilience
- for installation on sturdy walls / ceilings only
- universal mounting possibilities for all projectors on the threaded bushings with a distance of 180 to 320 mm
- content: projector mount, installation instructions and accessories

Technische Daten | Technical data

VESA Norm	300 x 300
VESA norm	300 x 300
Wandabstand	375 - 545 mm
Wall distance	375-545 mm
Neigbar (vertikal)	-30° bis +30°
Tiltable (vertically)	-30° to +30°
Schwenkbar (horizontal)	360°
Swivelling (horizontal)	360°
Belastbarkeit	15 kg
Capacity	15 kg
Farbe	Weiß
Colour	white

Produktmaterial	Stahl pulverbeschichtet
Material of product	Steel powder-coated
Gewicht	2.2 kg
Weight (set)	2.2 kg
Abmessungen (Breite)	270 mm
Dimensions (width)	270 mm
Abmessungen (Höhe)	240 mm
Dimensions (height)	240 mm
Abmessungen (Tiefe)	80 mm
Dimensions (depth)	80 mm
Garantie	5 Jahre Gewährleistung
Guarantee	5-year guarantee

Art. Nr.	EAN	Verpackungsart
Art. No.	EAN	Packaging
LWH210WD 511	4004005132380	Karton carton



LWH110B 011

PROFESSIONAL

Beamerhalterung | Projector Mount

für Deckenmontage | for Ceiling Mount

- Halterung zur Deckenbefestigung für einen Projektor
- Hohe mechanische Belastbarkeit
- Stabile Ausführung
- Montage nur an stabilen Decken
- Lieferumfang: Beamerhalterung, Montageanleitung und -zubehör

- holder for mounting a projector to the ceiling
- high mechanical resilience
- solid design
- installation on sturdy ceilings only
- content: projector mount, installation instructions and accessories

Technische Daten | Technical data

VESA Norm	230 x 230
VESA norm	230 x 230
Wandabstand	130 oder 200 mm
Wall distance	130 or 200 mm
Neigbar (vertikal)	-15° bis +15°
Tiltable (vertically)	-15° bis +15°
Schwenkbar (horizontal)	360°
Swivelling (horizontal)	360°
Belastbarkeit	10 kg
Capacity	10 kg
Farbe	Schwarz
Colour	black
Produktmaterial	Aluminium
Material of product	Aluminium
Gewicht	1.1 kg
Weight (set)	1.1 kg
Abmessungen (Breite)	305 mm
Dimensions (width)	305 mm
Abmessungen (Höhe)	200 mm
Dimensions (height)	200 mm
Abmessungen (Tiefe)	70 mm

Dimensions (depth)	70 mm
Garantie	5 Jahre Gewährleistung
Guarantee	5-year guarantee

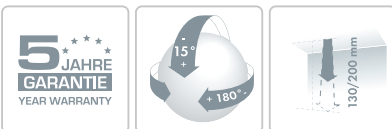
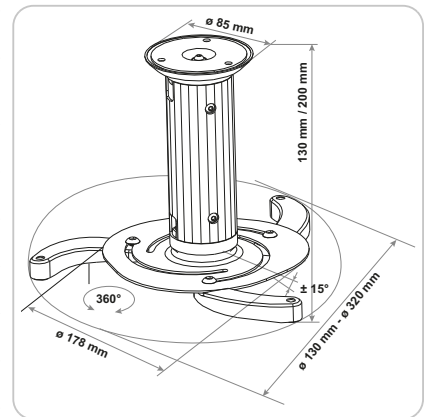

Art. Nr.	EAN	Verpackungsart
Art. No.	EAN	Packaging
LWH110B 011	4004005110654	Karton carton

TVB100 011

★★★
STANDARD**Boxenhalter | Loudspeaker Mounts**

mit verstellbarem Schraubsockel | with adjustable screw base

- Halterung mit Schraubsockel zur Befestigung von Lautsprechern
- Einfache Montage
- Stabile Ausführung
- Montage nur an stabilen Wänden
- Lieferumfang: 2x Boxenhalterung, Schraubenset
- mount with screw base for mounting loudspeakers
- easy installation
- solid design
- installation on sturdy walls only
- content: 2x loudspeaker mount, set of screws

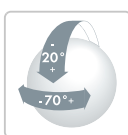
**Technische Daten | Technical data**

Wandabstand Wall distance	60 mm 60 mm
Neigbar (vertikal) Tiltable (vertically)	-20° bis +20° -20° to +20°
Drehbar (axial) Swivelling (axial)	-70° bis +70° -70° bis +70°
Belastbarkeit Capacity	3,5 kg (Gesamt) 3,5 kg (total)
Farbe Colour	Schwarz black
Produktmaterial Material of product	Kunststoff plastic
Gewicht Weight (set)	0,15 kg 0,15 kg
Abmessungen (Breite) Dimensions (width)	50 mm 50 mm
Abmessungen (Höhe) Dimensions (height)	87 mm 87 mm
Abmessungen (Tiefe) Dimensions (depth)	60 mm 60 mm

Guarantee 5-year guarantee

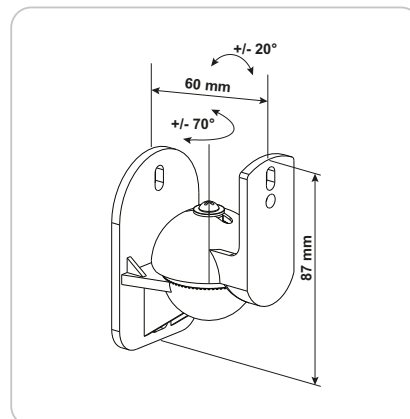

Garantie 5 Jahre Gewährleistung

Art. Nr. Art. No.	EAN EAN	Verpackungsart Packaging
TVB100 011	4004005101843	Karton carton

TVH6052 012

★★★
STANDARD**Klappbarer Gerätewandhalter | Hinged Wall Mount**

für Standgeräte (z.B. Mikrowelle) | for Stand-Alone Devices (e.g. Microwave Ovens)

- Halterung für ein Mikrowellengerät
- Auszug einstellbar
- Auch für andere Geräte (z.B. Dampfgarer) geeignet
- Lieferumfang: 2x Winkelhalterung, Schraubenset
- mount for microwave oven
- retainer can be pulled out as needed
- also suitable for other devices (e.g. steam cooker)
- content: 2x hinged retainer, set of screws

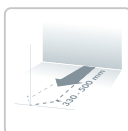
**Technische Daten | Technical data**

Wandabstand Wall distance	330 mm 330 mm
Tragarm Support arm	klappbar und verstellbar hinged and adjustable
Belastbarkeit Capacity	35 kg 35 kg
Farbe Colour	Weiß white
Produktmaterial Material of product	Metall pulverbeschichtet metal powder-coated
Gewicht Weight (set)	1,9 kg 1,9 kg
Abmessungen (Breite) Dimensions (width)	54 mm 54 mm
Abmessungen (Höhe) Dimensions (height)	220 mm 220 mm
Abmessungen (Tiefe) Dimensions (depth)	500 mm

Dimensions (depth) 500 mm

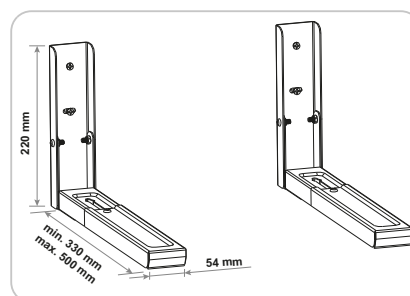
Garantie 5 Jahre Gewährleistung
Guarantee 5-year guarantee

Art. Nr. Art. No.	EAN EAN	Verpackungsart Packaging
TVH6052 012	4004005012095	Karton carton

LWK075-Serie

ULTIMATE

Aluminium Kabelkanal | Aluminium Cable Duct

mit schräger Kantenform und Klicksystem | with slanted edges and click system

- Einfache Montage durch CLICK & SAVE System
- Stabile Ausführung
- Elegantes und dezentes Design
- Lieferumfang: Kabelkanal, 5x Schrauben und Dübel
- easy installation through CLICK & SAVE system
- solid design
- elegant and discreet design
- content: cable raceway, 5x screw and dowel



Technische Daten | Technical data

Einsatzort Point of use	Innenbereich indoor use	Abmessungen (Höhe) Dimensions (height)	20 mm
Farbe Colour	Hellgrau light gray	Abmessungen (Breite) Dimensions (width)	60 mm
Produktmaterial Material of product	Aluminium pulverbeschichtet Aluminium powder-coated		
Gewicht Weight (set)	0,5 kg 0,5 kg		
Abmessungen (Länge) Dimensions (length)	0,75 m 0,75 m		

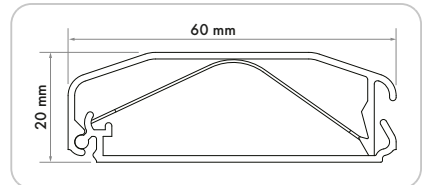

Art. Nr. Art. No.	EAN EAN	Verpackungsart Packaging
LWK075 512	4004005012156	Headercard header card
LWK075 513	4004005012149	Headercard header card

LWK110-Serie

PROFESSIONAL

Aluminium Kabelkanal | Aluminium Cable Duct

mit schräger Kantenform und Klicksystem | with slanted edges and click system

- Passende Kabelkanälecke: LWKE50
- Einfache Montage
- Stabile Ausführung
- Lieferumfang: Kabelkanal, 5x Schrauben und Dübel
- compatible angular cable raceway: LWKE50
- easy installation
- solid design
- content: cable raceway, 5x screw and dowel



EASY
INSTALLATION
CLICKSAFE

Technische Daten | Technical data

Einsatzort Point of use	Innenbereich indoor use	Abmessungen (Höhe) Dimensions (height)	26 mm
Farbe Colour	Silber silver	Abmessungen (Breite) Dimensions (width)	50 mm
Produktmaterial Material of product	Aluminium pulverbeschichtet Aluminium powder-coated		
Gewicht Weight (set)	0,6 kg 0,6 kg		
Abmessungen (Länge) Dimensions (length)	1,1 m 1,1 m		

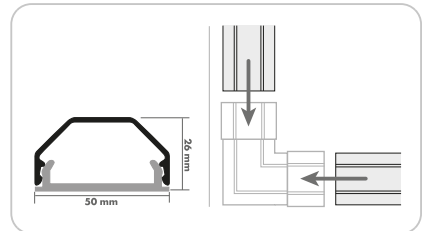

Art. Nr. Art. No.	EAN EAN	Verpackungsart Packaging
LWK110 011	4004005020502	Karton carton
LWK110 012	4004005020519	Karton carton

Produktempfehlung | Product Recommendation



LWKE50 011
Kunststoff Kabelkanälecke
mit schräger Kantenform und Klicksystem
Angular Plastic Cable Raceway
with slanted edges and click system



LWKE50 012
Kunststoff Kabelkanälecke
mit schräger Kantenform und Klicksystem
Angular Plastic Cable Raceway
with slanted edges and click system

LWKE-Serie

PROFESSIONAL

Kunststoff Kabelkanal | Angular Plastic Cable Raceway

mit schräger Kantenform und Klicksystem | with slanted edges and click system

- Passender Kabelkanal: LWK 110 Serie
- Kabelkanal im 90° Winkel für Installation in Raumecken
- Einfache Montage
- Stabile Ausführung
- compatible cable raceway: LWK 110 series
- 90° angled cable raceway for installation in corners
- easy installation
- solid design



Technische Daten | Technical data

Einsatzort Point of use	Innenbereich indoor use	Dimensions (depth)	100 mm
Farbe Colour	Silber silver		
Produktmaterial Material of product	Kunststoff plastic		
Gewicht Weight (set)	0,03 kg 0,03 kg		
Abmessungen (Breite) Dimensions (width)	50 mm 50 mm		
Abmessungen (Höhe) Dimensions (height)	26 mm 26 mm		
Abmessungen (Tiefe)	100 mm		

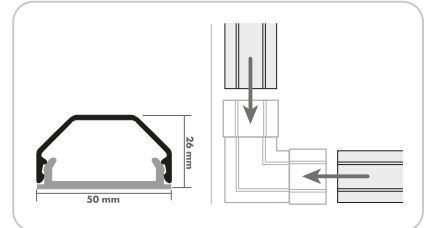

Art. Nr. Art. No.	EAN EAN	Verpackungsart Packaging
LWKE50 011	4004005020526	Knüpfblister SF clamshell SF
LWKE50 012	4004005020533	Knüpfblister SF clamshell SF

Produkttempfehlung | Product Recommendation

LWK110 011
Aluminium Kabelkanal
mit schräger Kantenform und Klicksystem
Aluminium Cable Duct
with slanted edges and click system

LWK110 012
Aluminium Kabelkanal
mit schräger Kantenform und Klicksystem
Aluminium Cable Duct
with slanted edges and click system

KBSL28-Serie

PROFESSIONAL

Kabelfspiral Schlauch (Ø 28 mm) | Spiral Cable Wrap (Ø 28 mm)

- Einfache Montage und Demontage
- Zum Bündeln von Kabeln
- Hohe Flexibilität und Biegsamkeit
- easy installation and deinstallation
- for bunching cables
- high flexibility



Technische Daten | Technical data

Verwendbarkeit Usability	mehrfach repeatedly	Gewicht Weight (set)	0,09 kg 0,09 kg
Farbe Colour	Grau gray	Abmessungen (Länge) Dimensions (length)	1,5 m 1,5 m
Produktmaterial Material of product	Kunststoff plastic		

Art. Nr. Art. No.	EAN EAN	Verpackungsart Packaging
KBSL28 041	4004005358162	Headercard header card
KBSL28 043	4004005358179	Headercard header card

VSXX-Serie

PROFESSIONAL

Gewebekabelschlauch | Mesh Cable Conduit

- Einfache Montage und Demontage
- Zum Bündeln von Kabeln
- Hohe Flexibilität und Biegsamkeit
- easy installation and deinstallation
- for bunching cables
- high flexibility



Technische Daten | Technical data

Verwendbarkeit Usability	mehrfach repeatedly	Material of product	textile
Farbe Colour	Weiß white	Abmessungen (Länge) Dimensions (length)	2 m 2 m
Produktmaterial	Gewebetextur		

Art. Nr. Art. No.	EAN EAN	Verpackungsart Packaging
VS20 032	4004005357929	Schweißblister SBL03 sealed blister SBL03
VS40 032	4004005357912	Schweißblister SBL02 sealed blister SBL02

LWHLED02

ULTIMATE

LED Ambientlicht "COLOR LED" | LED ambient lighting "COLOR LED"

zur indirekten Beleuchtung | for indirect lighting



- LED Lichtband zur indirekten Beleuchtung
- Befestigung durch Klebestreifen an der Rückseite
- Äußerst flexibel und leicht zu verlegen
- Extrem flache Bauform
- Lieferumfang: 2x LED Lichtband (0,5 m), USB Kabel (0,5 m), Infrarot-Empfänger, Fernbedienung, Batterie (CR 2025), Bedienungsanleitung
- LED light strip for indirect lighting
- Fixation by adhesive tape on the back
- extremely flexible and easy to lay
- extremely flat design
- Content: 2x LED light band (0.5 m), USB cable (0.5 m), the infrared receiver, remote control, battery (CR 2025), user manual



Technische Daten | Technical data

Leuchtmitteltyp Type of lamps	Leuchtdioden (LED) light-emitting diodes (LED)	Dimensions (length)	1 m
Batterietyp Battery type	CR 2025 CR 2025	Spannungsversorgung Power supply	USB USB
Abmessungen (Länge)	1 m	Lichtfarbe Colour shade	RGBW Multicolor RGBW Multicolor
Art. Nr. Art. No.	EAN EAN	Verpackungsart Packaging	
LWHLED02	4004005011661	Schiebeblister SF sliding blister SF	

LWHLED01

ULTIMATE

LED Ambientlicht "WHITE LED" | LED ambient lighting "WHITE LED"

zur indirekte Beleuchtung | for indirect lighting



- LED Lichtband zur indirekten Beleuchtung
- Befestigung durch Klebestreifen an der Rückseite
- Direkt über die Fernbedienung steuerbar
- Äußerst flexibel und leicht zu verlegen
- Extrem flache Bauform
- LED light strip for indirect lighting
- Fixation by adhesive tape on the back
- light bulbs can be operated via remote control directly
- extremely flexible and easy to lay
- extremely flat design



Technische Daten | Technical data

Leuchtmitteltyp Type of lamps	Leuchtdioden (LED) light-emitting diodes (LED)	Dimensions (length)	1 m
Batterietyp Battery type	CR 2025 CR 2025	Spannungsversorgung Power supply	USB USB
Abmessungen (Länge)	1 m	Lichtfarbe Colour shade	RGBW Multicolor RGBW Multicolor
Art. Nr. Art. No.	EAN EAN	Verpackungsart Packaging	
LWHLED01	4004005011678	Schiebeblister SF sliding blister SF	



Art.-Nr. item no.	Seite page
K	
KBSL28 041	25
4 004005 1358162	
KBSL28 043	25
4 004005 1358179	
L	
LWH030 011	15
4 004005 1030068	
LWH031 031	11
4 004005 1031027	
LWH032 031	11
4 004005 1032024	
LWH040 011	12
4 004005 1040227	
LWH050 011	9
4 004005 1050066	
LWH110B 011	22
4 004005 1110654	
LWH130 511	13
4 004005 1132342	
LWH1323 511	20
4 004005 1132304	
LWH14225 513	14
4 004005 1011579	
LWH1737 511	21
4 004005 1132311	
LWH210WD 511	22
4 004005 1132380	
LWH2337 011	19
4 004005 1324204	
LWH240 511	12
4 004005 1132359	
LWH25535 513	8
4 004005 1011586	
LWH310WD	21
4 004005 1011654	
LWH3263 011	19
4 004005 1326307	
LWH350 511	9
4 004005 1132366	
LWH35535 513	7
4 004005 1011593	
LWH4275 511	17
4 004005 1132328	
LWH603D 011	5
4 004005 1603798	

Art.-Nr. item no.	Seite page
LWH7075 511	16
4 004005 132335	
LWHD5530 511	3
4 004005 1011647	
LWHD7050 513	6
4 004005 1011623	
LWHF2725 513	20
4 004005 1011548	
LWHF5535 513	18
4 004005 1012187	
LWHF8035 513	18
4 004005 1012194	
LWHLED01	26
4 004005 1011678	
LWHLED02	26
4 004005 1011661	
LWHS2725 513	10
4 004005 1011562	
LWHT246 513	4
4 004005 1011494	
LWHT2725 513	15
4 004005 1011555	
LWHT5535 513	17
4 004005 1010893	
LWHT7050 513	16
4 004005 1010695	
LWK075 512	24
4 004005 1012156	
LWK075 513	24
4 004005 1012149	
LWK110 011	24
4 004005 1020502	
LWK110 012	24
4 004005 1020519	
LWKE50 011	25
4 004005 1020526	
LWKE50 012	25
4 004005 1020533	
T	
TVB100 011	23
4 004005 101843	
TVH6052 012	23
4 004005 1012095	
V	
VS20 032	25
4 004005 1357929	

Art.-Nr. item no.	Seite page
VS40 032	25
4 004005 1357912	

Detaillierte Informationen zu unseren Produkten finden sie auf
www.schwaiger.de

SCHWAIGER[®]

Schwaiger GmbH
Würzburger Straße 17
90579 Langenzenn

E-Mail info@schwaiger.de
Internet www.schwaiger.de

VERTRIEB

E-Mail vertrieb@schwaiger.de
Telefon +49 9101 702 0
Fax +49 9101 702 256

HÄNDLER:

Irrtümer, Abweichungen und Änderungen bei den technischen Angaben und Abbildungen vorbehalten. Es gelten unsere Allgemeinen Bedingungen für Lieferungen und Leistungen.

DRUCKS0742_a

